

Cassina

635 BLACK RED AND BLUE (ZEILMAKER VERSION)

Family RIETVELD

Catalogue I Maestri

Year of design 1920

Year of production 2015

One of the versions of the iconic model dated 1918.

The structure is in black-stained beechwood with white contrasting parts.

Seat and back in green lacquered multiplywood.

The armchair can have a single seat and backrest cushion in fabric or leather.

The Black Red and Blue (Zeilmaker version) born from Rietveld's chromatic experimentation

While researching the origins of the Red and Blue model in collaboration with the Rietveld heirs, it emerged that the key idea of the first prototypes was based on the concept of spatial organisation expressed through the monochrome tones of its elements. The first version was in fact produced in 1918 in completely unpainted wood.

In the following years Rietveld proposed various examples, either monochrome or painted in different colours, depending on the requirements of his customers and the interiors for which the chairs were intended. As such, it comes as no surprise to find this 1920s version, presented as part of Cassina's MutAzioni selection, created for the school teacher Wicher Zeilmaker with a black frame with white ends and a dark green painted seat and backrest.

It was Rietveld's ever-increasing involvement in the De Stijl movement that led him to also use primary colours on this model in 1923, and as such the chair became a veritable manifesto for the emerging neoplastic movement. Initially dubbed Slat chair, Rietveld only gave it the name Red and Blue in the 1950s following its chromatic evolution.

The various owners of the different examples used the chair as an abstract-realist sculpture in their interiors and, in some cases, as a simple tool for sitting on, adding cushions to make it more comfortable, just like Cassina offers for the Black Red and Blue today.

Gallery

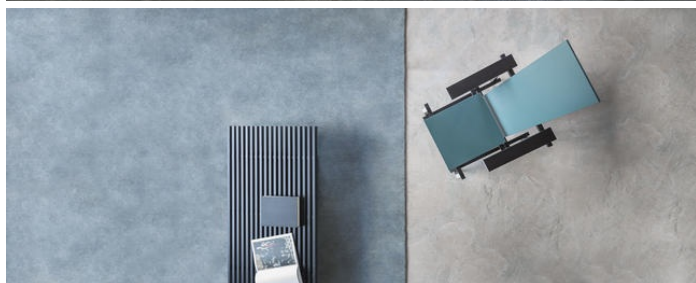

Dimensions

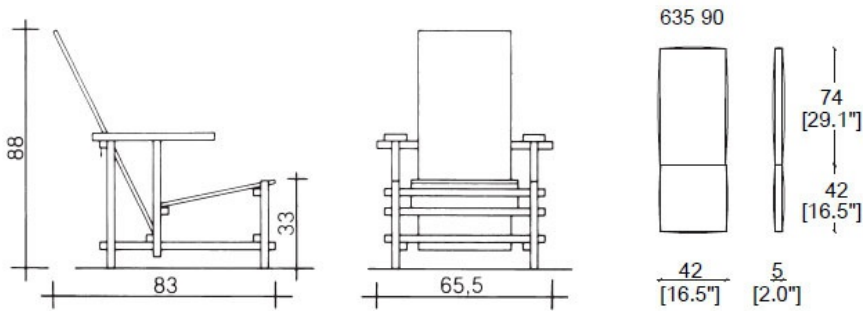

Designer



Gerrit Thomas Rietveld

Gerrit Thomas Rietveld, born in Utrecht on 24 June 1888, seems possessed of two personalities, each so distinct that one might take his work to be that of more than one artist. The first personality is that seen in the craftsman cabinet-maker working in a primordial idiom, re-inventing chairs and other furniture as if no one had ever built them before him and following a structural code all of his own; the second is that of the architect working with elegant formulas, determined to drive home the rationalist and neoplastic message in the context of European architecture. The two activities alternate, overlap, and fuse in a perfect osmosis unfolding then into a logical sequence. In 1918 Rietveld joined the "De Stijl" movement which had sprung up around the review of that name founded the year before by Theo van Doesburg. The group assimilated and translated into ideology certain laws on the dynamic breakdown of compositions (carrying them to an extreme) that had already been expressed in painting by the cubists: the "De Stijl" artists also carefully studied the architectonic lesson taught by the great Frank Lloyd Wright, whose influence was widely felt in Europe at that time.

Collaborating first with Robert van't Hoff and Vilmos Huszar, then with Theo van Doesburg and Cornelius van Eesteren, Rietveld soon became one of the most distinguished interpreters of the neoplastic message.

Among his most important works are:

the Schröder house at Utrecht (1924); the "Row Houses" at Utrecht (1931-34); the Dutch pavilion at the Venice Biennial (1954); the sculpture pavilion in the Rijksmuseum Kröller-Müller at Otterloo and the Van Gogh Museum in Amsterdam (1955). Out of his equally important furniture, Cassina has chosen for its own production: the "Red and Blue" (1918), the "Zig-Zag" (1934), the "Schröder 1" (1923), the "Utrecht" (1935)